

3.2 Main Circuit Wiring

This section describes the functions, specifications, and procedures required to safely and properly wire the main circuit of the drive.

NOTICE: Do not solder the ends of wire connections to the drive. Soldered wiring connections can loosen over time. Improper wiring practices could result in drive malfunction due to loose terminal connections.

◆ Main Circuit Terminal Functions

Table 3.1 Main Circuit Terminal Functions

Terminal	Type	Function	Reference
R/L1	Main circuit power supply input	Connects line power to the drive. Drives with single-phase 200 V input power use terminals R/L1 and S/L2 only (T/L3 must not be used).	–
S/L2			
T/L3			
U/T1	Drive output	Connects to the motor.	36
V/T2			
W/T3			
B1	Braking resistor	Available for connecting a braking resistor or the braking resistor unit option.	–
B2			
+1	DC reactor connection	These terminals are shorted at shipment. Remove the shorting bar between +1 and +2 when connecting a DC reactor to this terminal.	–
+2			
+1	DC power supply input	For connecting a DC power supply.	–
–			
 (2 terminals)	Ground	Grounding Terminal For 200 V class: 100 Ω or less For 400 V class: 10 Ω or less	36

◆ Wire Gauges and Tightening Torque

Select the appropriate wires and crimp terminals from [Table 3.2](#) through [Table 3.4](#).

- Note:**
1. Wire gauge recommendations based on drive continuous current ratings using 75 °C 600 Vac vinyl-sheathed wire assuming ambient temperature within 30 °C and wiring distance less than 100 m.
 2. Terminals +1, +2, –, B1 and B2 are for connecting optional devices such as a DC reactor or braking resistor. Do not connect other non-specified devices to these terminals.

- Consider the amount of voltage drop when selecting wire gauges. Increase the wire gauge when the voltage drop is greater than 2% of motor rated voltage. Ensure the wire gauge is suitable for the terminal block. Use the following formula to calculate the amount of voltage drop:
- Line drop voltage (V) = $\sqrt{3}$ x wire resistance (Ω/km) x wire length (m) x current (A) x 10^{-3}
- Refer to instruction manual TOBPC72060000 for braking unit or braking resistor unit wire gauges.
- [Refer to UL Standards Compliance on page 156](#) for information on UL compliance.

3.2 Main Circuit Wiring

■ Single-Phase 200 V Class

Table 3.2 Wire Gauge and Torque Specifications

Model CIMR-V□BA	Terminal	Screw Size	Tightening Torque N·m (lb.in.)	Applicable Gauge mm ² (AWG)	Recommended Gauge mm ² (AWG)
0001 0002 0003	R/L1, S/L2, U/T1, V/T2, W/T3, -, +1, +2, B1, B2, ⊕	M3.5	0.8 to 1.0 (7.1 to 8.9)	0.75 to 2.0 (18 to 14)	2 (14)
0006	R/L1, S/L2, U/T1, V/T2, W/T3, -, +1, +2, B1, B2, ⊕	M4	1.2 to 1.5 (10.6 to 13.3)	2.0 to 5.5 (14 to 10)	2 (14)
0010	R/L1, S/L2, U/T1, V/T2, W/T3, ⊕	M4	1.2 to 1.5 (10.6 to 13.3)	2.0 to 5.5 (14 to 10)	3.5 (12)
	-, +1, +2, B1, B2	M4	1.2 to 1.5 (10.6 to 13.3)	2.0 to 5.5 (14 to 10)	5.5 (10)
0012	R/L1, S/L2, U/T1, V/T2, W/T3, -, +1, +2, B1, B2, ⊕	M4	1.2 to 1.5 (10.6 to 13.3)	2.0 to 5.5 (14 to 10)	5.5 (10)
0018	R/L1, S/L2, U/T1, V/T2, W/T3, -, +1, +2, B1, B2, ⊕	M5	2 to 2.5 (17.7 to 22.1)	3.5 to 8 (12 to 8)	8 (8)

■ Three-Phase 200 V Class

Table 3.3 Wire Gauge and Torque Specifications

Model CIMR-V□2A	Terminal	Screw Size	Tightening Torque N·m (lb.in.)	Applicable Gauge mm ² (AWG)	Recommended Gauge mm ² (AWG)
0001 0002 0004 0006	R/L1, S/L2, T/L3, U/T1, V/T2, W/ T3, -, +1, +2, B1, B2, ⊕	M3.5	0.8 to 1.0 (7.1 to 8.9)	0.75 to 2.0 (18 to 14)	2 (14)
0010	R/L1, S/L2, T/L3, U/T1, V/T2, W/ T3, -, +1, +2, B1, B2	M4	1.2 to 1.5 (10.6 to 13.3)	2.0 to 5.5 (14 to 10)	2 (14)
	⊕	M4	1.2 to 1.5 (10.6 to 13.3)	2.0 to 5.5 (14 to 10)	3.5 (12)
0012	R/L1, S/L2, T/L3, U/T1, V/T2, W/ T3, -, +1, +2, B1, B2, ⊕	M4	1.2 to 1.5 (10.6 to 13.3)	2.0 to 5.5 (14 to 10)	3.5 (12)
0020	R/L1, S/L2, T/L3, U/T1, V/T2, W/ T3, -, +1, +2, B1, B2, ⊕	M4	1.2 to 1.5 (10.6 to 13.3)	2.0 to 5.5 (14 to 10)	5.5 (10)
0030	R/L1, S/L2, T/L3, U/T1, V/T2, W/ T3, -, +1, +2	M4	1.2 to 1.5 (10.6 to 13.3)	5.5 to 14 (10 to 6)	8 (8)
	B1, B2	M4	1.2 to 1.5 (10.6 to 13.3)	2.0 to 5.5 (14 to 10)	5.5 (10)
	⊕	M5	2 to 2.5 (17.7 to 22.1)	5.5 to 14 (10 to 6)	8 (8)
0040	R/L1, S/L2, T/L3, U/T1, V/T2, W/ T3, -, +1, +2	M4	1.2 to 1.5 (10.6 to 13.3)	5.5 to 14 (10 to 6)	14 (6)
	B1, B2	M4	1.2 to 1.5 (10.6 to 13.3)	2.0 to 5.5 (14 to 10)	5.5 (10)
	⊕	M5	2 to 2.5 (17.7 to 22.1)	5.5 to 14 (10 to 6)	8 (8)

Model CIMR-V□2A	Terminal	Screw Size	Tightening Torque N·m (lb.in.)	Applicable Gauge mm ² (AWG)	Recommended Gauge mm ² (AWG)
0056	R/L1, S/L2, T/L3, U/T1, V/T2, W/T3, -, +1, +2	M6	4 to 6 (35.4 to 53.1)	14 to 22 (6 to 4)	22 (4)
	B1, B2	M5	2 to 2.5 (17.7 to 22.1)	5.5 to 8 (10 to 8)	8 (8)
	⊕	M6	4 to 6 (35.4 to 53.1)	14 to 22 (6 to 4)	22 (4)
0069	R/L1, S/L2, T/L3, U/T1, V/T2, W/T3, -, +1, +2	M8	9 to 11 (79.7 to 11.0)	8 to 38 (8 to 2)	38 (2)
	B1, B2	M5	2 to 2.5 (17.7 to 22.1)	8 to 14 (8 to 6)	14 (6)
	⊕	M6	4 to 6 (35.4 to 53.1)	8 to 22 (8 to 4)	22 (4)

■ Three-Phase 400 V Class

Table 3.4 Wire Gauge and Torque Specifications

Model CIMR-V□4A	Terminal	Screw Size	Tightening Torque N·m (lb.in.)	Applicable Gauge mm ² (AWG)	Recommended Gauge mm ² (AWG)
0001 0002 0004 0005 0007	R/L1, S/L2, T/L3, U/T1, V/T2, W/T3, -, +1, +2, B1, B2, ⊕	M4	1.2 to 1.5 (10.6 to 13.3)	2.0 to 5.5 (14 to 10)	2 (14)
0009	R/L1, S/L2, T/L3, U/T1, V/T2, W/T3, -, +1, +2, B1, B2	M4	1.2 to 1.5 (10.6 to 13.3)	2.0 to 5.5 (14 to 10)	2 (14)
	⊕	M4	1.2 to 1.5 (10.6 to 13.3)	2.0 to 5.5 (14 to 10)	3.5 (12)
0011	R/L1, S/L2, T/L3, U/T1, V/T2, W/T3, -, +1, +2, B1, B2	M4	1.2 to 1.5 (10.6 to 13.3)	2.0 to 5.5 (14 to 10)	2 (14)
	⊕	M4	1.2 to 1.5 (10.6 to 13.3)	2.0 to 5.5 (14 to 10)	3.5 (12)
0018	R/L1, S/L2, T/L3, U/T1, V/T2, W/T3, -, +1, +2, B1, B2	M4	1.2 to 1.5 (10.6 to 13.3)	2.0 to 5.5 (14 to 10)	5.5 (10)
	⊕	M5	2 to 2.5 (17.7 to 22.1)	5.5 to 14 (10 to 6)	5.5 (10)
0023	R/L1, S/L2, T/L3, U/T1, V/T2, W/T3, -, +1, +2	M4	1.2 to 1.5 (10.6 to 13.3)	5.5 to 14 (10 to 6)	8 (8)
	B1, B2	M4	1.2 to 1.5 (10.6 to 13.3)	2.0 to 5.5 (14 to 10)	5.5 (10)
	⊕	M5	2 to 2.5 (17.7 to 22.1)	5.5 to 14 (10 to 6)	5.5 (10)
0031	R/L1, S/L2, T/L3, U/T1, V/T2, W/T3, -, +1, +2	M5	2 to 2.5 (17.7 to 22.1)	5.5 to 14 (10 to 6)	8 (8)
	B1, B2	M5	2 to 2.5 (17.7 to 22.1)	5.5 to 8 (10 to 8)	8 (8)
	⊕	M6	4 to 6 (35.4 to 53.1)	5.5 to 14 (10 to 6)	8 (8)

3.2 Main Circuit Wiring

Model CIMR- V□4A	Terminal	Screw Size	Tightening Torque N•m (lb.in.)	Applicable Gauge mm ² (AWG)	Recommended Gauge mm ² (AWG)
0038	R/L1, S/L2, T/L3, U/T1, V/T2, W/ T3; -, +1, +2	M5	2 to 2.5 (17.7 to 22.1)	5.5 to 14 (10 to 6)	14 (6)
	B1, B2	M5	2 to 2.5 (17.7 to 22.1)	5.5 to 8 (10 to 8)	8 (8)
	⊕	M6	4 to 6 (35.4 to 53.1)	5.5 to 14 (10 to 6)	8 (8)

◆ Main Circuit Terminal Power Supply and Motor Wiring

This section outlines the various steps, precautions, and checkpoints for wiring the main circuit terminals and motor terminals.

NOTICE: When connecting the motor to the drive output terminals U/T1, V/T2, and W/T3, the phase order for the drive and motor should match. Failure to comply with proper wiring practices may cause the motor to run in reverse if the phase order is backward.

NOTICE: Do not connect phase-advancing capacitors or LC/RC noise filters to the output circuits. Improper application of noise filters could result in damage to the drive.

NOTICE: Do not connect the AC power line to the output motor terminals of the drive. Failure to comply could result in death or serious injury by fire as a result of drive damage from line voltage application to output terminals.

■ Cable Length Between Drive and Motor

When the cable length between the drive and the motor is too long (especially at low frequency output), note that the cable voltage drop may cause reduced motor torque. Drive output current will increase as the leakage current from the cable increases. An increase in leakage current may trigger an overcurrent situation and weaken the accuracy of the current detection.

Adjust the drive carrier frequency according to the following table. If the motor wiring distance exceeds 100 m because of the system configuration, reduce the ground currents.

Refer to [Table 3.5](#) to set the carrier frequency to an appropriate level.

Table 3.5 Cable Length Between Drive and Motor

Cable Length	50 m or less	100 m or less	Greater than 100 m
Carrier Frequency	15 kHz or less	5 kHz or less	2 kHz or less

Note: When setting carrier frequency, calculate the cable length as the total distance of wiring to all connected motors when running multiple motors from a single drive.

■ Ground Wiring

Follow the precautions to wire the ground for one drive or a series of drives.

WARNING! *Electrical Shock Hazard.* Always use a ground wire that complies with technical standards on electrical equipment and minimize the length of the ground wire. Improper equipment grounding may cause dangerous electrical potentials on equipment chassis, which could result in death or serious injury.

WARNING! *Electrical Shock Hazard. Be sure to ground the drive ground terminal. (200 V Class: Ground to 100 Ω or less, 400 V Class: Ground to 10 Ω or less). Improper equipment grounding could result in death or serious injury by contacting ungrounded electrical equipment.*

NOTICE: *Do not share the ground wire with other devices such as welding machines or large-current electrical equipment. Improper equipment grounding could result in drive or equipment malfunction due to electrical interference.*

NOTICE: *When using more than one drive, ground multiple drives according to instructions. Improper equipment grounding could result in abnormal operation of drive or equipment.*

Refer to **Figure 3.3** when using multiple drives. Do not loop the ground wire.

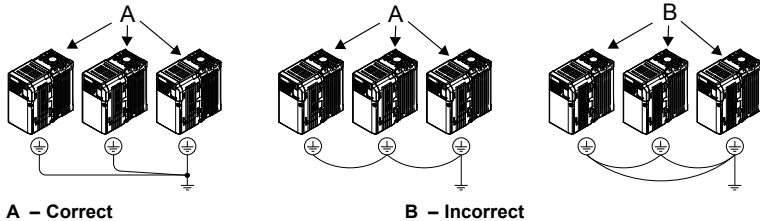
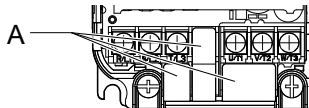

Figure 3.3 Multiple Drive Wiring

■ Wiring the Main Circuit Terminal

WARNING! *Electrical Shock Hazard. Shut off the power supply to the drive before wiring the main circuit terminals. Failure to comply may result in death or serious injury.*

Note: A cover placed over the DC Bus and braking circuit terminals prior to shipment helps prevent miswiring. Cut away covers as needed for terminals with a needle-nose pliers.



A - Protective Cover to Prevent Miswiring

Note: The ground terminal screw on IP20/NEMA Type 1 holds the protective cover in place.

3.3 Control Circuit Wiring

◆ Control Circuit Terminal Block Functions

Drive parameters determine which functions apply to the multi-function digital inputs (S1 to S7), multi-function digital outputs (MA, MB), multi-function pulse inputs and outputs (RP, MP) and multi-function photocoupler outputs (P1, P2). The default is called out next to each terminal in [Figure 3.1](#).

WARNING! Sudden Movement Hazard. Always check the operation and wiring of control circuits after being wired. Operating a drive with untested control circuits could result in death or serious injury.

WARNING! Confirm the drive I/O signals and external sequence before starting test run. Setting parameter A1-06 may change the I/O terminal function automatically from the factory setting. [Refer to Application Selection on page 65](#). Failure to comply may result in death or serious injury.

■ Input Terminals

Table 3.6 Control Circuit Input Terminals

Type	No.	Terminal Name (Function)	Function (Signal Level) Default Setting
Multi-Function Digital Inputs	S1	Multi-function input 1 (Closed: Forward run, Open: Stop)	Photocoupler 24 Vdc, 8 mA Note: Drive preset to sinking mode. When using source mode, set DIP switch S3 to allow for a 24 Vdc ($\pm 10\%$) external power supply. Refer to Sinking/Sourcing Mode Switch on page 44 .
	S2	Multi-function input 2 (Closed: Reverse run, Open: Stop)	
	S3	Multi-function input 3 (External fault (N.O.))	
	S4	Multi-function input 4 (Fault reset)	
	S5	Multi-function input 5 (Multi-step speed reference 1)	
	S6	Multi-function input 6 (Multi-step speed reference 2)	
	S7	Multi-function input 7 (Jog reference)	
	SC	Multi-function input common (Control common)	Sequence common
Safe Disable Input	HC	Power supply for safe disable input	+24 Vdc (max 10 mA allowed)
	H1	Safe disable input	Open: Output disabled Closed: Normal operation Note: Disconnect wire jumper between HC and H1 when using the safe disable input. The wire length should not exceed 30 m.

Type	No.	Terminal Name (Function)	Function (Signal Level) Default Setting
Main Frequency Reference Input	RP	Multi-function pulse train input (frequency reference)	Response frequency: 0.5 to 32 kHz (Duty Cycle: 30 to 70%) (High level voltage: 3.5 to 13.2 Vdc) (Low level voltage: 0.0 to 0.8 Vdc) (input impedance: 3 kΩ)
	+V	Analog input power supply	+10.5 Vdc (max allowable current 20 mA)
	A1	Multi-function analog input 1 (frequency reference)	Input voltage 0 to +10 Vdc (20 kΩ) resolution 1/1000
	A2	Multi-function analog input 2 (frequency reference)	Input voltage or input current (Selected by DIP switch S1 and H3-01) 0 to +10 Vdc (20 kΩ), Resolution: 1/1000 4 to 20 mA (250 Ω) or 0 to 20 mA (250 Ω), Resolution: 1/500
	AC	Frequency reference common	0 Vdc

Output Terminals

Table 3.7 Control Circuit Output Terminals

Type	No.	Terminal Name (Function)	Function (Signal Level) Default Setting
Multi-Function Digital Output	MA	N.O. (fault)	Digital output 30 Vdc, 10 mA to 1 A; 250 Vac, 10 mA to 1 A Minimum load: 5 Vdc, 10 mA (reference value)
	MB	N.C. output (fault)	
	MC	Digital output common	
Multi-Function Photocoupler Output	P1	Photocoupler output 1 (During run)	Photocoupler output 48 Vdc, 2 to 50 mA
	P2	Photocoupler output 2 (Frequency agree)	
	PC	Photocoupler output common	
Monitor Output	MP	Pulse train output (Output frequency)	32 kHz (max)
	AM	Analog monitor output	0 to 10 Vdc (2 mA or less) Resolution: 1/1000
	AC	Monitor common	0 V

Connect a suppression diode as shown in *Figure 3.4* when driving a reactive load such as a relay coil. Ensure the diode rating is greater than the circuit voltage.

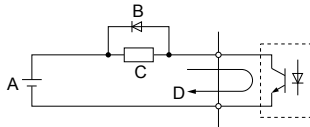

A – External power, 48 V max.
B – Suppression diode

C – Coil
D – 50 mA or less

Figure 3.4 Connecting a Suppression Diode

3.3 Control Circuit Wiring

Serial Communication Terminals

Table 3.8 Control Circuit Terminals: Serial Communications

Type	No.	Signal Name	Function (Signal Level)	
MEMOBUS/ Modbus Communication	R+	Communications input (+)	MEMOBUS/Modbus communication: Use a RS-485 or RS-422 cable to connect the drive.	RS-485/422 MEMOBUS/ Modbus communication protocol 115.2 kbps (max.)
	R-	Communications input (-)		
	S+	Communications output (+)		
	S-	Communications output (-)		
	IG	Shield ground	0 V	

Terminal Configuration

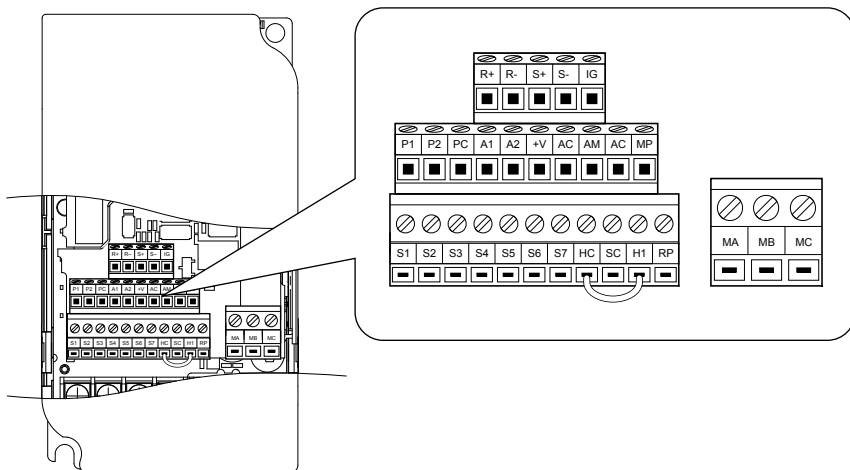

Figure 3.5 Removable Control Circuit Terminal Block
(CIMR-VA□□□□□□□□; CIMR-VU□□□□□□□□)

Wire Size and Torque Specifications

Select appropriate wire type and size from [Table 3.9](#). For simpler and more reliable wiring, crimp ferrules to the wire ends. Refer to [Table 3.10](#) for ferrule terminal types and sizes.

Table 3.9 Wire Size and Torque Specifications (Same for All Models)

Terminal	Screw Size	Tightening Torque N·m	Tightening Torque (in-lbs)	Bare Wire Terminal		Ferrule-Type Terminal		Wire Type
				Applicable wire size mm ² (AWG)	Recomm. mm ² (AWG)	Applicable wire size mm ² (AWG)	Recomm. mm ² (AWG)	
MA, MB, MC	M3	0.5 to 0.6	4.4 to 5.3	Stranded: 0.25 to 1.5 (24 to 16) Single: 0.25 to 1.5 (24 to 16)	0.75 (18)	0.25 to 1.0 (24 to 17)	0.5 (20)	Shielded line, etc.
SI-S7, SC, RP, +V, A1, A2, AC, HC, H1, P1, P2, PC, MP, AM, AC, S+, S-, R+, R-, IG	M2	0.22 to 0.25	1.9 to 2.2	Stranded: 0.25 to 1.0 (24 to 18) Single: 0.25 to 1.5 (24 to 16)	0.75 (18)	0.25 to 0.5 (24 to 20)	0.5 (20)	

■ Ferrule-Type Wire Terminations

Crimp a ferrule to signal wiring to improve wiring simplicity and reliability. Use CRIMPFOX ZA-3, a crimping tool manufactured by PHOENIX CONTACT.

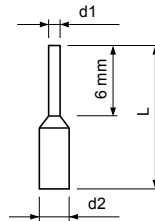

Figure 3.6 Ferrule Dimensions

Table 3.10 Ferrule Terminal Types and Sizes

Size mm ² (AWG)	Type	L (mm)	d1 (mm)	d2 (mm)	Manufacturer
0.25 (24)	AI 0.25-6YE	10.5	0.8	1.8	PHOENIX CONTACT
0.34 (22)	AI 0.34-6TQ	10.5	0.8	1.8	
0.5 (20)	AI 0.5-6WH	12	1.1	2.5	
0.75 (18)	AI 0.75-6GY	12	1.3	2.8	
1.0	AI 1-6RD	12	1.5	3.0	

◆ Wiring Procedure

This section describes the proper procedures and preparations for wiring the control terminals.

3.3 Control Circuit Wiring

WARNING! *Electrical Shock Hazard. Do not remove covers or touch the circuit boards while the power is on. Failure to comply could result in death or serious injury.*

NOTICE: *Separate control circuit wiring from main circuit wiring (terminals R/L1, S/L2, T/L3, B1, B2, U/T1, V/T2, W/T3, -, +1, +2) and other high-power lines. Improper wiring practices could result in drive malfunction due to electrical interference.*

NOTICE: *Separate wiring for digital output terminals MA, MB and MC from wiring to other control circuit lines. Improper wiring practices could result in drive or equipment malfunction or nuisance trips.*

NOTICE: *Use a class 2 power supply (UL standard) when connecting to the control terminals. Improper application of peripheral devices could result in drive performance degradation due to improper power supply.*

NOTICE: *Insulate shields with tape or shrink tubing to prevent contact with other signal lines and equipment. Improper wiring practices could result in drive or equipment malfunction due to short circuit.*

NOTICE: *Connect the shield of shielded cable to the appropriate ground terminal. Improper equipment grounding could result in drive or equipment malfunction or nuisance trips.*

Wire the control terminals using **Figure 3.7** as a guide. Prepare the ends of the control circuit wiring as shown in **Figure 3.8**. Refer to **Wire Size and Torque Specifications on page 40**.

NOTICE: *Do not tighten screws beyond the specified tightening torque. Failure to comply may damage the terminal block.*

NOTICE: *Use shielded twisted-pair cables as indicated to prevent operating faults. Improper wiring practices could result in drive or equipment malfunction due to electrical interference.*

Connect control wires as shown in the following figure:

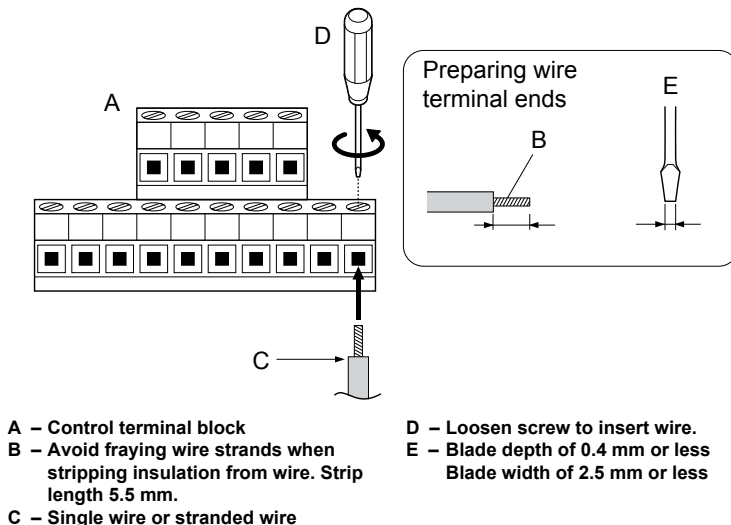
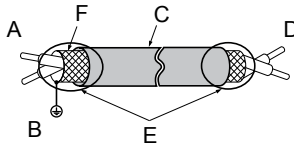

Figure 3.7 Terminal Board Wiring Guide



- A – Drive side
- B – Connect shield to ground terminal of drive.
- C – Insulation
- D – Control device side
- E – Shield sheath (Insulate with tape)
- F – Shield

Figure 3.8 Preparing the Ends of Shielded Cables

3.4 I/O Connections

◆ Sinking/Sourcing Mode Switch

Set the DIP switch S3 on the front of the drive to switch the digital input terminal logic between sinking mode and sourcing mode; the drive is preset to sinking mode.

Table 3.11 Sinking/Sourcing Mode Setting

Set Value	Details
SINK	Sinking Mode (0 V common): default setting
SOURCE	Sourcing Mode (+24 V common)

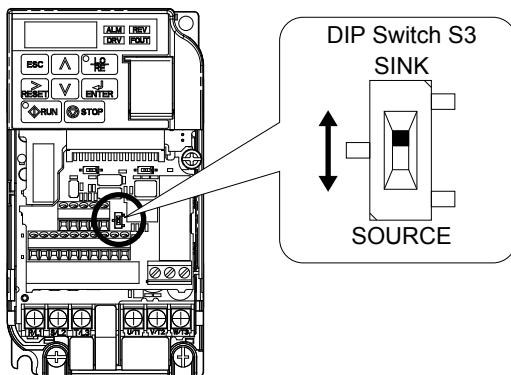

Figure 3.9 DIP Switch S3

■ Transistor Input Signal Using 0 V Common/Sink Mode

When controlling the digital inputs by NPN transistors (0 V common/sinking mode), set the DIP switch S3 to SINK and use the internal 24 V power supply.

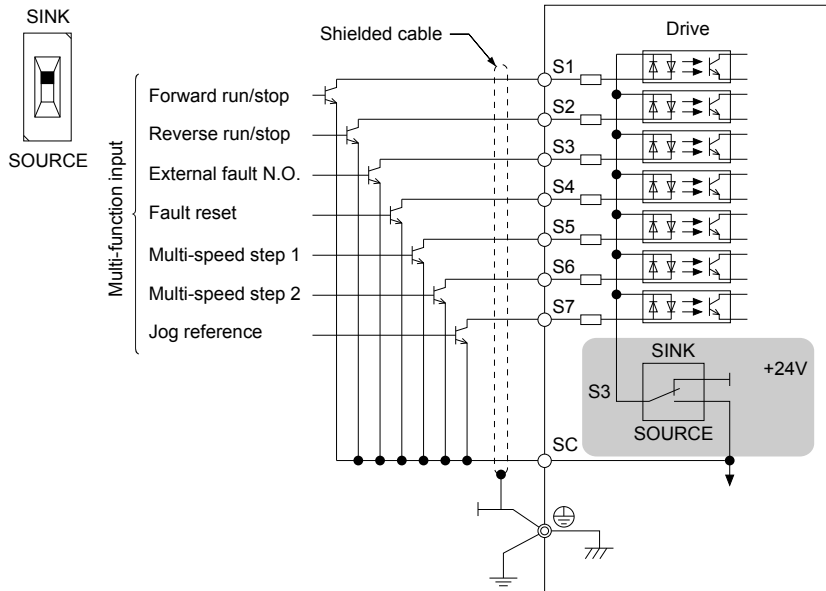

Figure 3.10 Sinking Mode: Sequence from NPN Transistor (0 V Common)

■ Transistor Input Signal Using +24 V Common/Source Mode

When controlling digital inputs by PNP transistors (+24 V common/sourcing mode), set the DIP switch S3 to SOURCE and use an external 24 V power supply.

3.4 I/O Connections

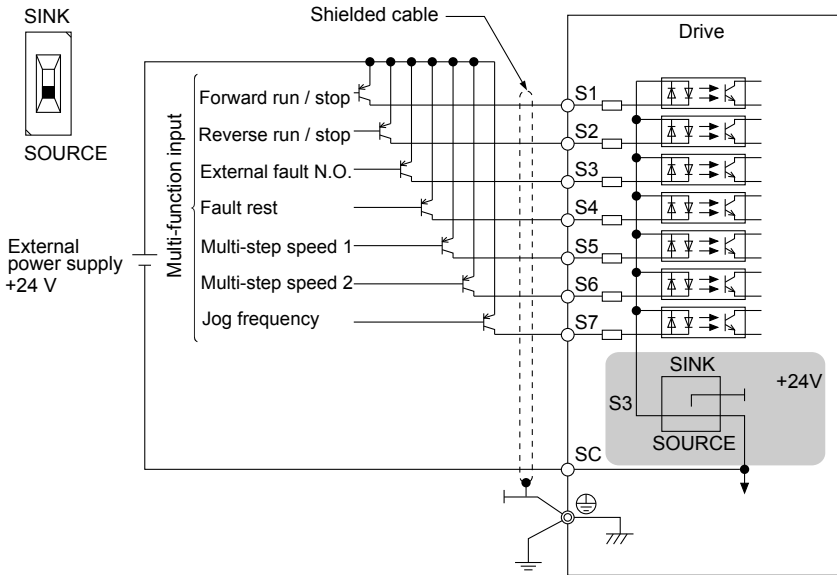

Figure 3.11 Source Mode: Sequence from PNP Transistor (+24 V Common)

3.5 Main Frequency Reference

◆ DIP Switch S1 Analog Input Signal Selection

The main frequency reference can either be a voltage or current signal input. For voltage signals both analog inputs, A1 and A2, can be used, for current signals A2 must be used.

When using input A2 as a voltage input, set DIP switch S1 to “V” (left position) and program parameter H3-09 to “0” (0 to +10 Vdc with lower limit) or “1” (0 to +10 Vdc without lower limit).

To use current input at terminal A2, set the DIP switch S1 to “I” (default setting) and set parameter H3-09 = “2” or “3” (4-20 mA or 0-20 mA). Set parameter H3-10 = “0” (frequency reference).

Note: If Terminals A1 and A2 are both set for frequency reference (H3-02 = 0 and H3-10 = 0), the addition of both input values builds the frequency reference.

Table 3.12 Frequency Reference Configurations

Voltage Input	Current Input

3.5 Main Frequency Reference

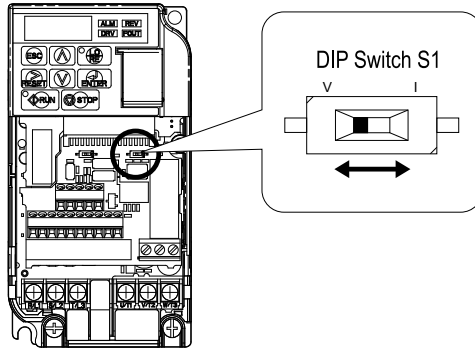

Figure 3.12 DIP Switch S1

Table 3.13 DIP Switch S1 Settings

Setting Value	Description
V (left position)	Voltage input (0 to 10 V)
I (right position)	Current input (4 to 20 mA or 0 to 20 mA): default setting

Table 3.14 Parameter H3-09 Details

No.	Parameter Name	Description	Setting Range	Default Setting
H3-09	Frequency ref. (current) terminal A2 signal level selection	Selects the signal level for terminal A2. 0: 0 to +10 V, unipolar input (with lower limit) 1: 0 to +10 V, bipolar input (no lower limit) 2: 4 to 20 mA 3: 0 to 20 mA	0 to 3	2